

**NOTE: DO NOT DISCARD the Parts List from the Instruction Bulletin. Place the Parts List in the appropriate place in the machine manual for future reference. Retaining the Parts List will make it easier to reorder individual parts and will save the cost of ordering an entire kit.**

*NOTE: Numbers in parenthesis ( ) are reference numbers for parts listed in Bill of Materials.*

Installation instructions for **kit number 9008624**

## SYNOPSIS:

This kit contains the parts needed to replace the seal between the vacuum fan filter housing and vacuum fan mounting plate on S30 machines. Please follow step-by-step instructions.

## SPECIAL TOOLS / CONSIDERATIONS: NONE

(Estimated time to complete: 2 hours)

## PREPARATION:

1. Park the machine on a clean level surface, turn off the machine, remove the key, and set the parking brake.

**FOR SAFETY: Before leaving or servicing machine, stop on level surface, turn off machine, set parking brake, and remove key.**

## INSTALLATION:

1. Remove the M8 hex screws holding the vacuum fan mounting plate onto the vacuum fan filter housing and carefully lower the mounting plate away from the filter housing. Set the M8 hex screws and the flat washers aside. Refer to Fig. 2.

*NOTE: Do not disconnect any hydraulic hoses from the hydraulic motor mounted on the vacuum fan mounting plate. No hydraulic hoses or fittings need to be disconnected to install the vacuum fan housing seal kit.*

2. Remove the rubber seal from the vacuum fan filter housing. Refer to Fig. 2.
3. Use isopropyl alcohol to clean any remaining residue from the around the area where the rubber seal was removed in the previous step.

4. Hold a straight edge across the outer edge of the vacuum fan filter housing and measure the perpendicular distance from the inner impeller surface to the flat edge setting across the edge of the the vacuum fan filter housing. Refer to Fig. 1.

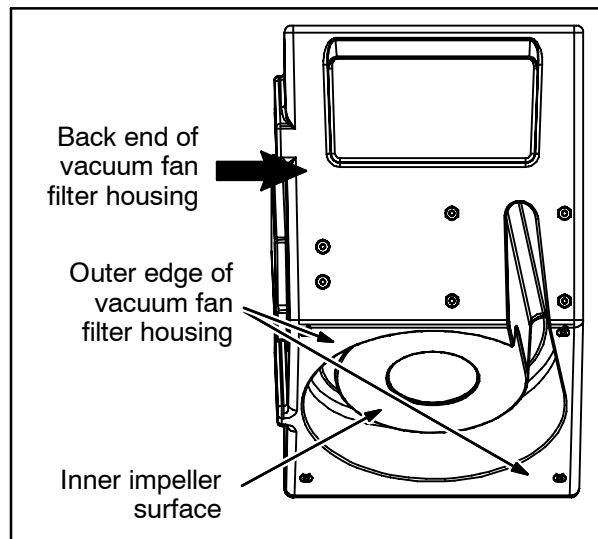

**FIG. 1**

5. If the measurement is 1 9/16" (40 mm) install rubber seal (1) onto the vacuum fan filter housing. Refer to Fig. 1 and Fig. 2.

If the measurement is 1 13/16" (47 mm) install rubber seal (2) onto the vacuum fan filter housing. Refer to Fig. 1 and Fig. 2.

6. Reinstall the vacuum fan mounting plate onto the vacuum fan filter housing. Discard the four flat washers previously used as spacers if rubber seal (2) was installed onto the vacuum fan filter housing. Refer to Fig. 2.

7. Remove the shaker assembly and filter from the vacuum fan filter housing. Spin the impeller by hand to ensure it does not rub against the rubber seal. Reinstall the filter and shaker assembly.

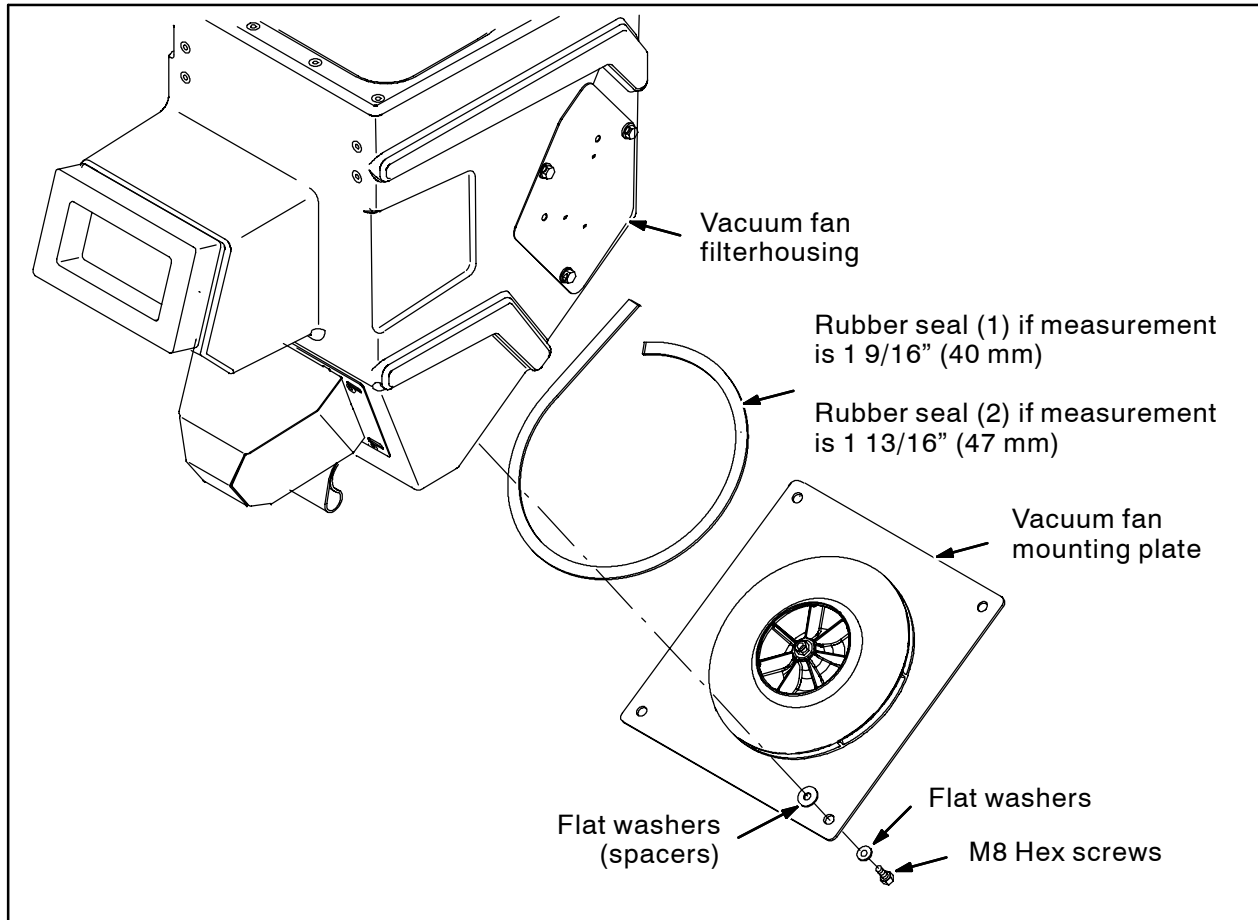

FIG. 2

Bill Of Materials For Seal Kit, Vacuum Hsng, Replmt - 9008624

Ref.	Tennant Part No.	Description	Qty.
▽	9008624	Seal Kit, Vacuum Hsng, Replmt	1
▲	1 1053361	Seal, Afrmkt, Rbr, Clsd, Adh, 05FT	1
▲	2 367564	Seal, Rbr, Clsd, .13, .38W 60.0L, Adh	1

TENNANT COMPANY  
P. O. Box 1452  
Minneapolis, MN 55440-1452